

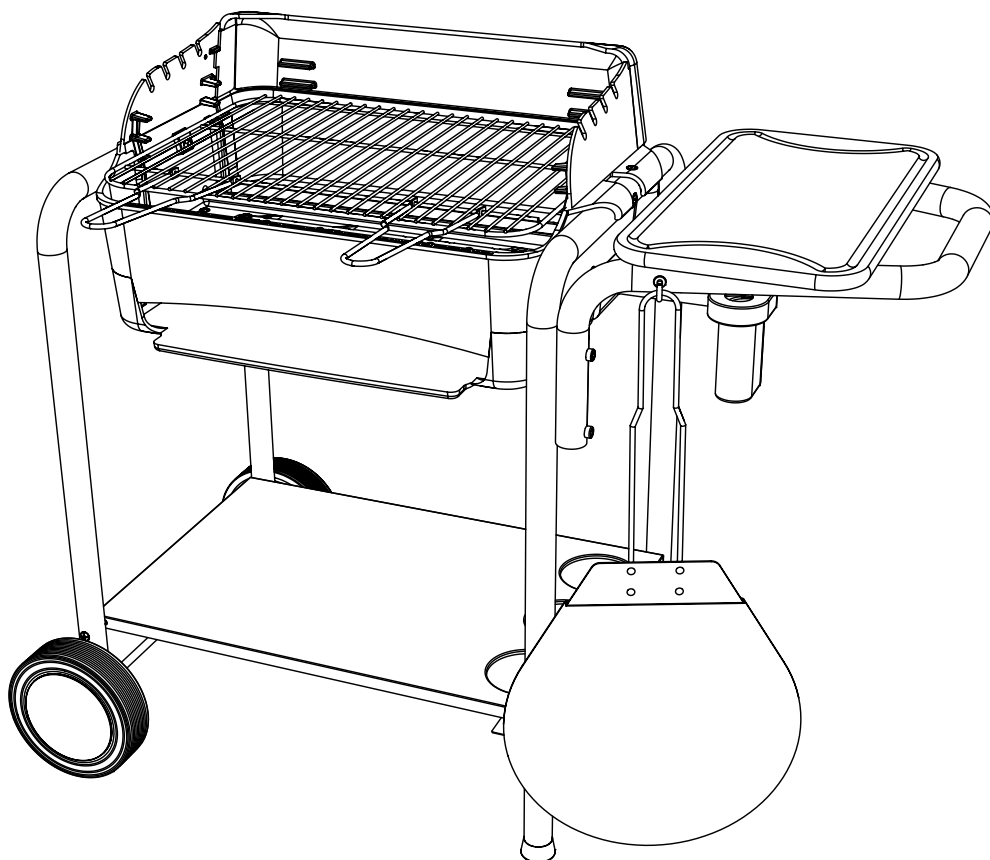

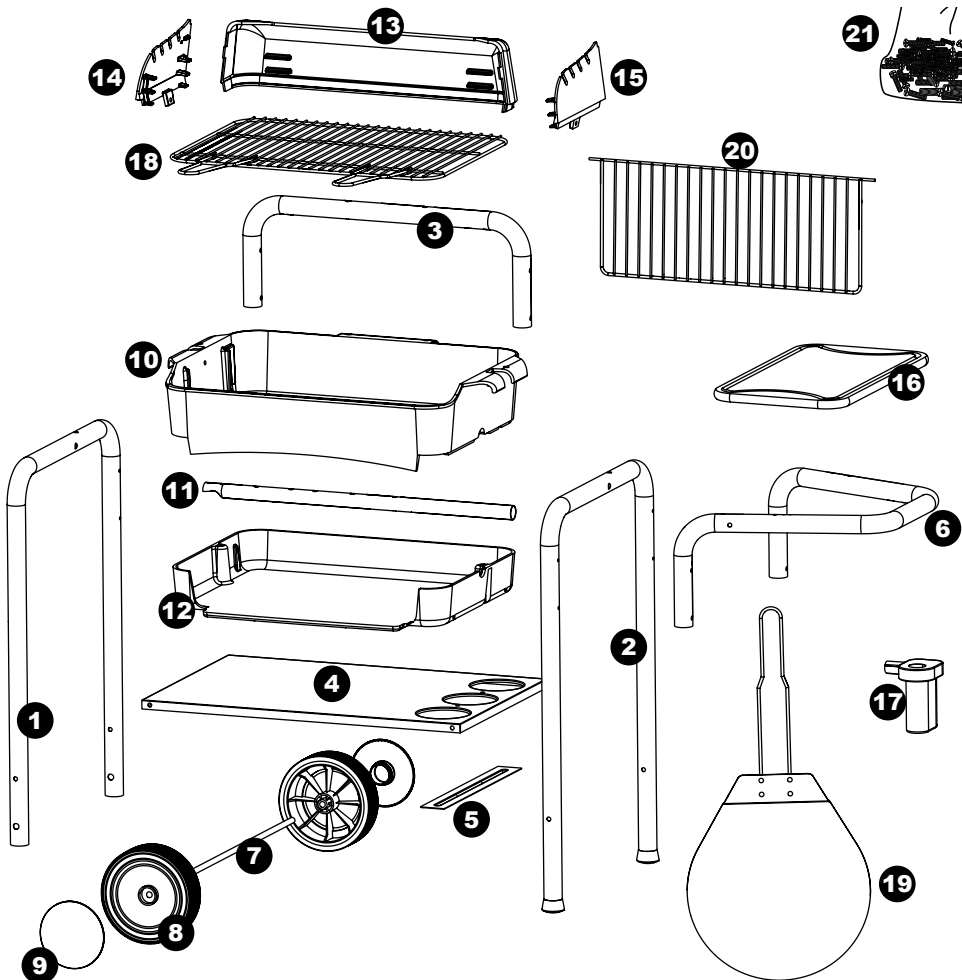







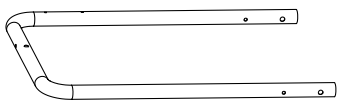

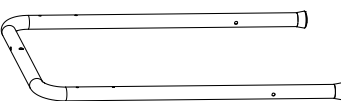

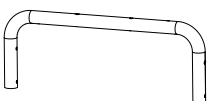

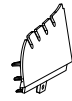
# TOM 399100 (NF)

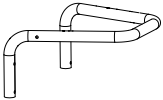

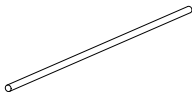
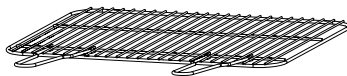

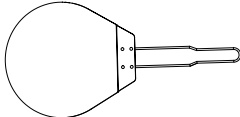
	8 x 55	2		6 x 35	1
	6 x 65	2		6 x 20	3
	6 x 50	2		6 x 10	2
	6 x 45	8		Ø6	2
	6 x 45	4		Ø6	17
	6 x 40	5		Ø10	2
				5	1

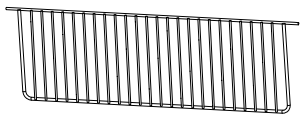
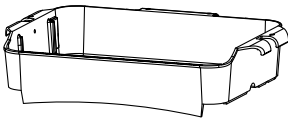

<b>1</b>		x 1	<b>12</b>		x 1
<b>2</b>		x 1	<b>13</b>		x 1
<b>3</b>		x 1	<b>14</b>		x 1
<b>4</b>		x 1	<b>15</b>		x 1
<b>5</b>		x 1	<b>16</b>		x 1
<b>6</b>		x 1	<b>17</b>		x 1
<b>7</b>		x 1	<b>18</b>		x 1
<b>8</b>		x 2	<b>19</b>		x 1
<b>9</b>		x 2	<b>20</b>		x 1
<b>10</b>		x 1	<b>21</b>		x 1
<b>11</b>		x 1			

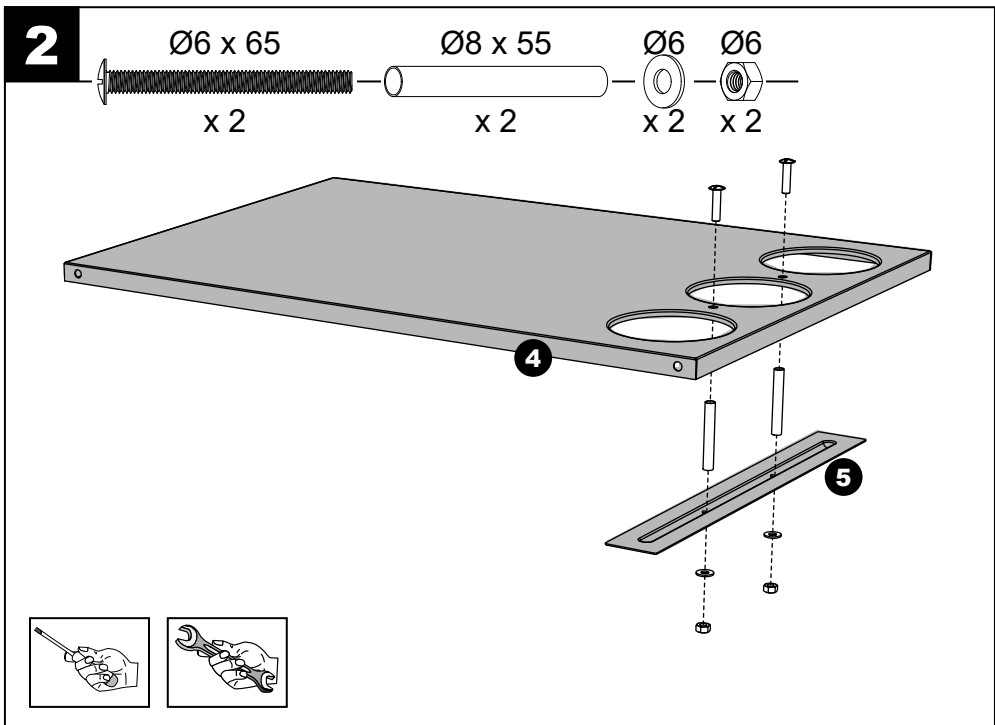
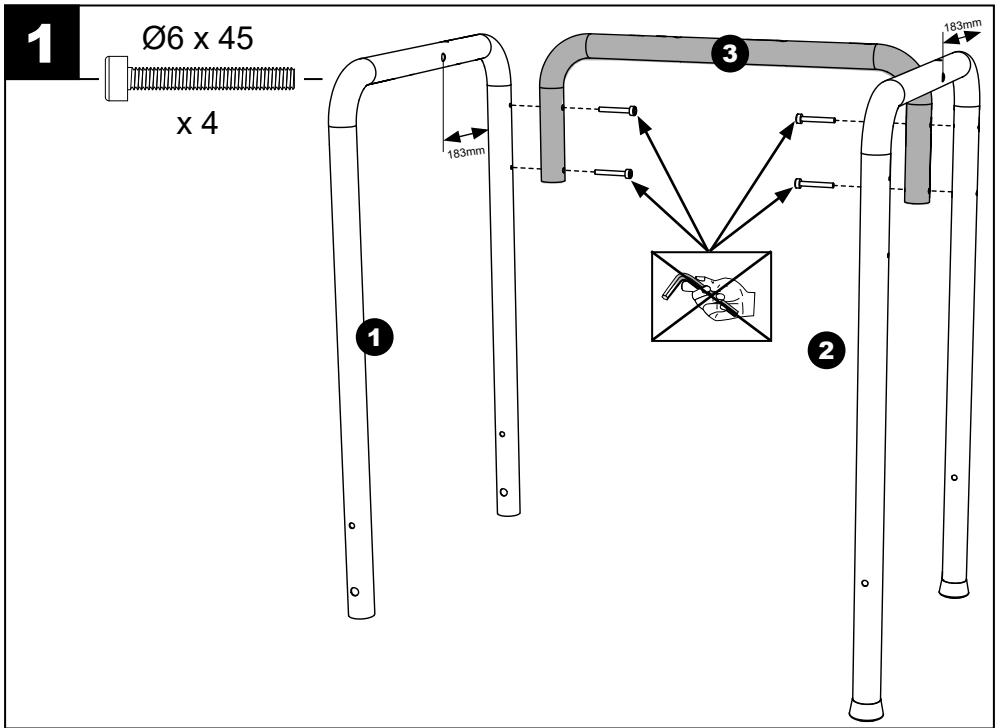

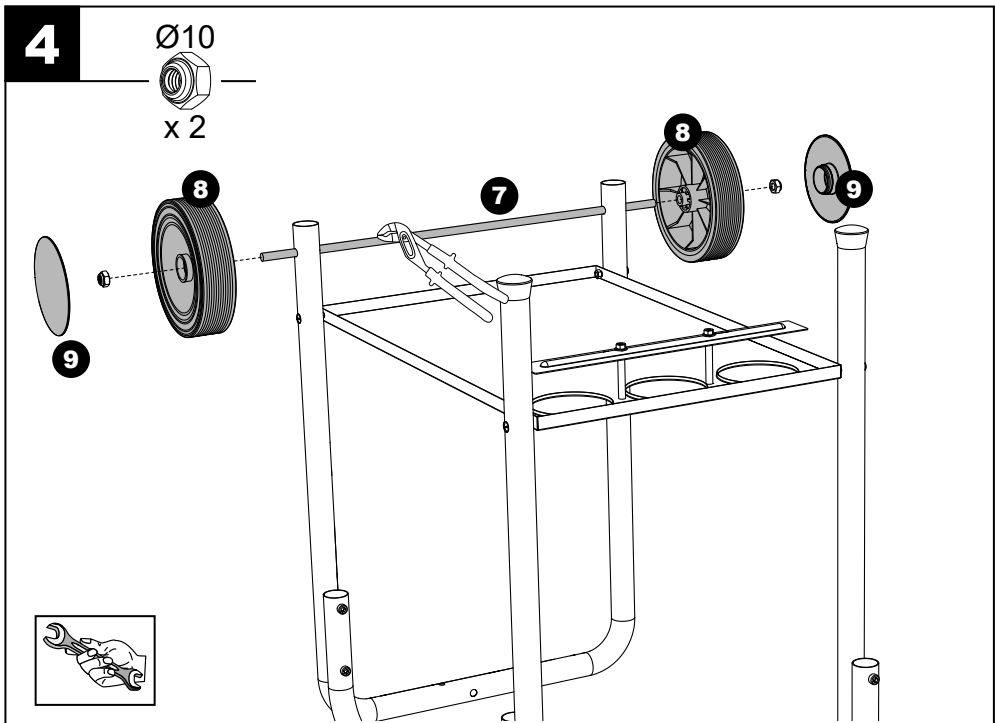
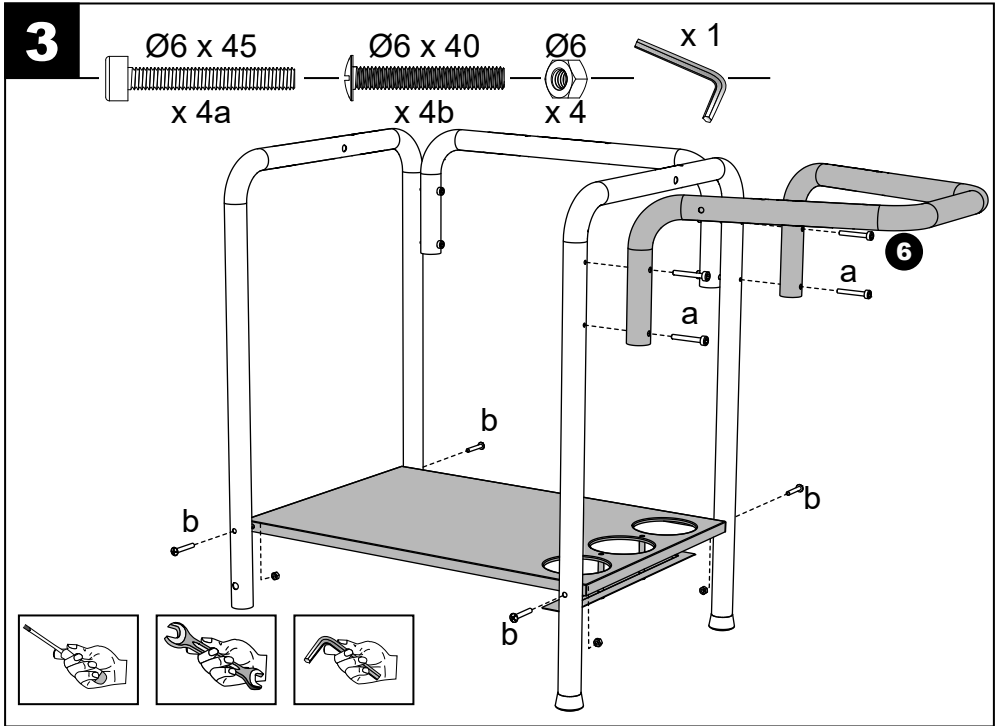

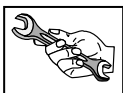
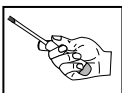
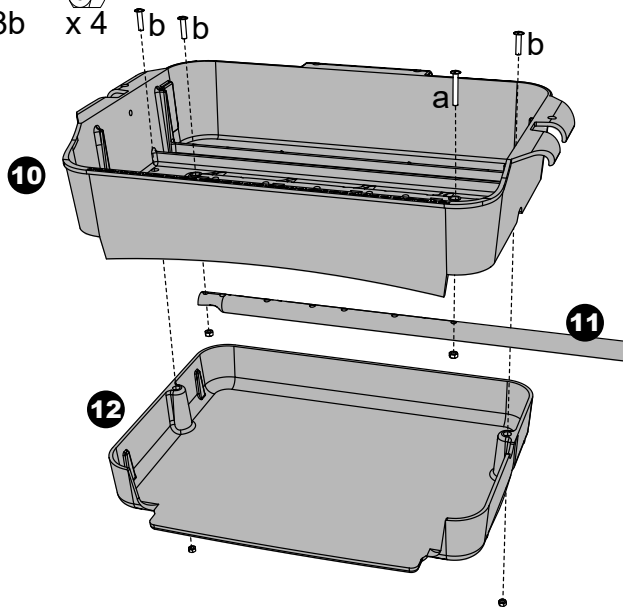
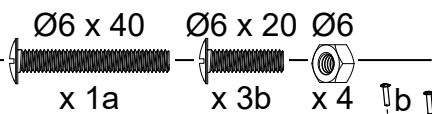
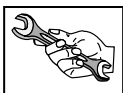
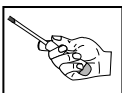
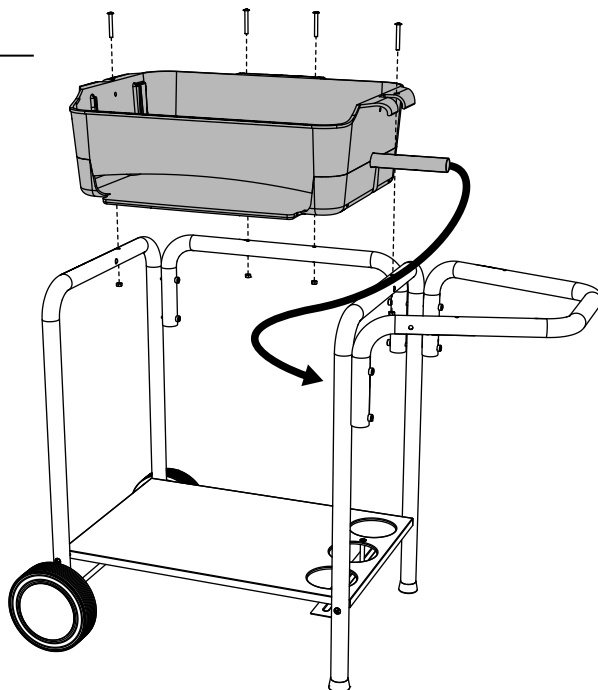
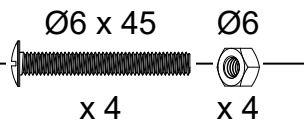
**5****6**

**7**

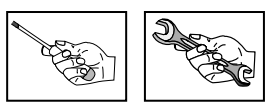
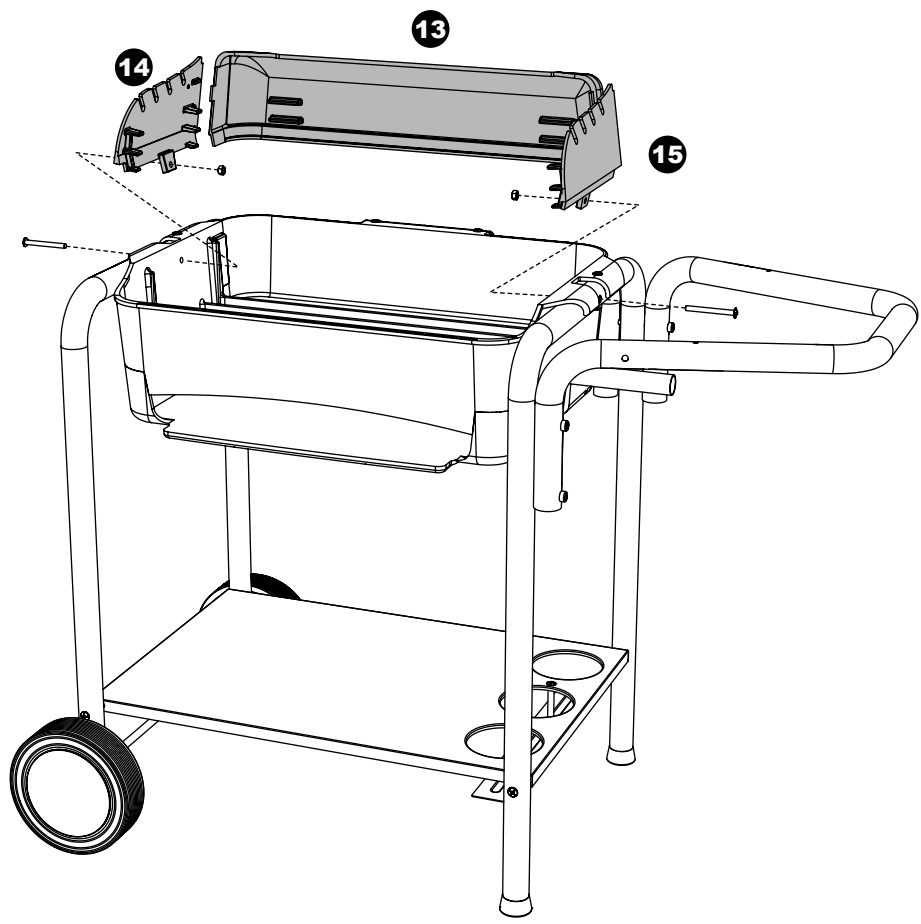
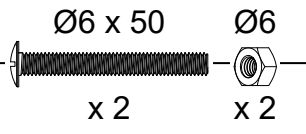

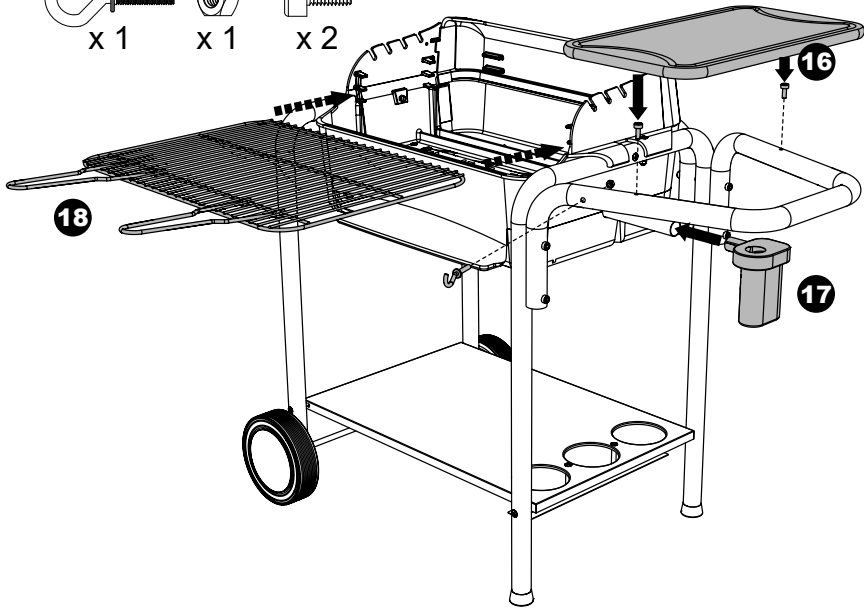
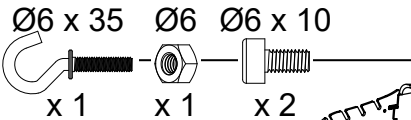
**8**

**FR** La soufflerie fonctionne grâce à 2 piles de 1,5 Volts référence LR20. (Durée de service environ 10 heures) (Piles non fournies). Ne jamais utiliser la soufflerie au-delà de 5 minutes. Lorsque vous n'utilisez pas la soufflerie, enlevez celle-ci du tube, afin d'éviter sa détérioration.

**GB** The blower is powered by two 1.5V batteries reference LR20. Never leave the blower running for more than five minutes. When you are not using the blower, remove it from the tube, to avoid it being damaged.

**DE** Das Gebläsesystem wird mit zwei 1.5 V Batterien LR 20 betrieben. Nie das Gebläsesystem länger als 5 Minuten in Betrieb lassen. Wenn das Gebläse-system nicht in Be-trieb ist, sollte man es aus dem Lüftungs-rohr herausnehmen, um eine Beschädi-gung zu vermeiden

**IT** Il soffietto funziona grazie a due pile da 1.5 volt di tipo LR20. Non utilizzate mai il soffietto per più di cinque minuti. Se non utilizzate il soffietto, toglietelo dal tubo per evitare che si deteriori.

**PT** Os foles funcionam graças a duas pilhas de 1.5 volts referência LR20. Nunca utilizar os foles mais de cinco minutos. Quando utiliza os foles, retire-os do tubo para evitar a sua deterioração.

**ES** El soplador funciona con dos pilas de 1.5 volts referencia LR20. Nunca utilizar el soplador más de 5 minutos. Cuando no se utilice el soplador es conveniente quitarlo del tubo para evitar su deterioro.

**NL** Het blaastoestel werkt op twee batterijen van 1,5 volt referentie LR20. Gebruik het blaastoestel nooit langer dan 5 minuten. Als u het blaastoestel niet gebruikt dient u het van de buis te verwijderen om beschadigingen te voorkomen.

**PL** Dmuchawa działa na dwie baterie 1,5 V typu LR20. Nie należy używać dmuchawy ponad pięć minut. Jeśli dmuchawa nie funkcjonuje, w celu uniknięcia uszkodzenia jej należy wyjąć ją z rury.



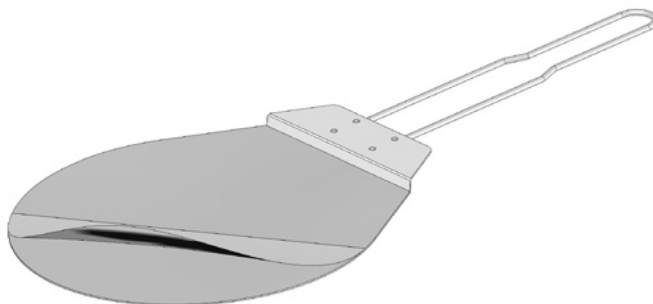

- **FR** Enlever la protection plastique de la plaque en inox avant la première utilisation.
- **GB** Remove the plastic protection sheet from the stainless steel plate before first use.
- **DE** Entfernen Sie vor der ersten Verwendung bitte die Plastikschutzverpackung des Edelstahlbleches.
- **IT** Prima di utilizzare per la prima volta, rimuovere la protezione di plastica dalla piastra inox.
- **PT** Retirar a protecção de plástico da placa em inox antes da primeira utilização.
- **ES** Quitar el plástico protector de la placa inox antes de la primera utilización
- **NL** Voor het eerste gebruik de plastic bescherming van de inox plaat verwijderen.
- **PL** Przed pierwszym użyciem zdjąć plastikową osłonę z płyty z nierdzewnej stali.

